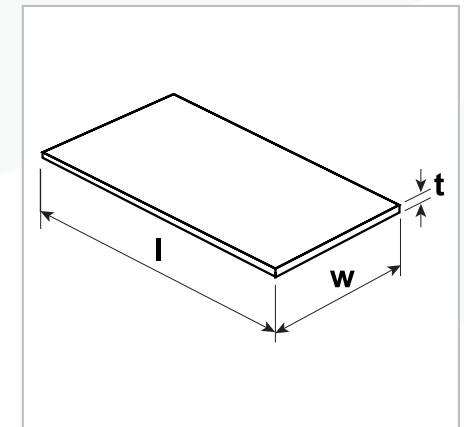

PLATE PRODUCTS REFERENCE GUIDE: MILD STEEL PLATE - 250 GRADE

Designation	Weight	Thickness t	Width w	Length l	Designation	Weight	Thickness t	Width w	Length l
	kg/m ²	mm	mm	mm		kg/m ²	mm	mm	mm
2400x6000	47.10	6	2400	6000	3000x12000	157.00	20	3000	12000
2400x9000	47.10	6	2400	9000	3200x12000	157.00	20	3200	12000
3000x9000	47.10	6	3000	9000	2400x6000	196.25	25	2400	6000
3000x12000	47.10	6	3000	12000	3000x9000	196.25	25	3000	9000
3200x12000	47.10	6	3200	12000	3000x12000	196.25	25	3000	12000
2400x6000	62.80	8	2400	6000	3200x12000	196.25	25	3200	12000
2400x9000	62.80	8	2400	9000	2400x6000	219.80	28	2400	6000
3000x9000	62.80	8	3000	9000	2400x6000	251.20	32	2400	6000
3000x12000	62.80	8	3000	12000	3000x9000	251.20	32	3000	9000
3200x12000	62.80	8	3200	12000	2400x9000	282.60	36	2400	9000
2400x6000	78.50	10	2400	6000	2400x6000	314.00	40	2400	6000
2400x9000	78.50	10	2400	9000	2400x9000	353.25	45	2400	9000
3000x9000	78.50	10	3000	9000	2400x6000	392.50	50	2400	6000
3000x12000	78.50	10	3000	12000	2400x9000	392.50	50	2400	9000
3200x12000	78.50	10	3200	12000	2400x6000	431.75	55	2400	6000
2400x6000	94.20	12	2400	6000	2400x6000	471.00	60	2400	6000
2400x9000	94.20	12	2400	9000	2400x6000	549.50	70	2400	6000
3000x12000	94.20	12	3000	12000	2400x5200	628.00	80	2400	5200
3200x12000	94.20	12	3200	12000	1800x6000	706.50	90	1800	6000
2400x6000	125.60	16	2400	6000	2400x4000	785.00	100	2400	4000
2400x9000	125.60	16	2400	9000	2400x3700	863.50	110	2400	3700
3000x12000	125.60	16	3000	12000	2400x3400	942.00	120	2400	3400
3200x12000	125.60	16	3200	12000	2400x3100	1020.50	130	2400	3100
2400x6000	157.00	20	2400	6000	2400x2700	1177.50	150	2400	2700
3000x9000	157.00	20	3000	9000					



■ Manufactured in accordance with the requirements of Australian Standard AS/NZS 3678 in Grade 250.

